

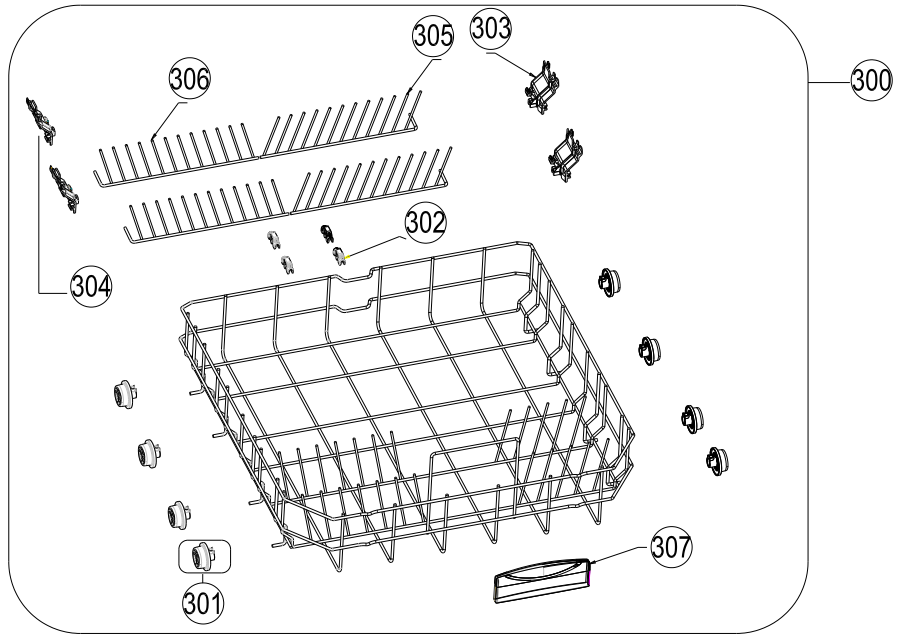

VESTEL DISWASHER MACH .

LOWER BASKET GROUP

**CUSTOMER
SUPPORT**

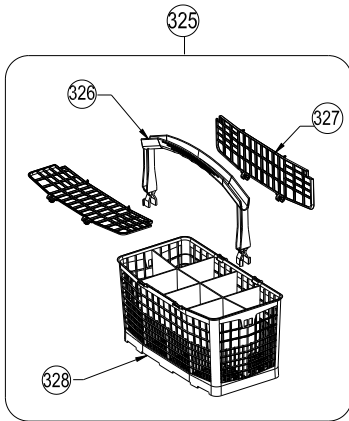

NO	PART NAME
300	LOWER BASKET GR- (301-302-303-304-305-306-307)
301	LOWER BASKET WHEEL GR
302	FOLDABLE COMBS HOLDER PLS
303	FOLDING SPIKES MECHANISM-RIGHT
304	FOLDING SPIKES MECHANISM-LEFT
305	FOLDDOWN COMB-RIGHT
306	FOLD DOWN COMB-LEFT
307	ALOWER BASKET PLASTIC HANDLE
325	PLASTIC SET BASKET (326-327-328)
326	PLASTIC BASKET HANDLE
327	PLASTIC BASKET COVER
328	PLASTIC BASKET

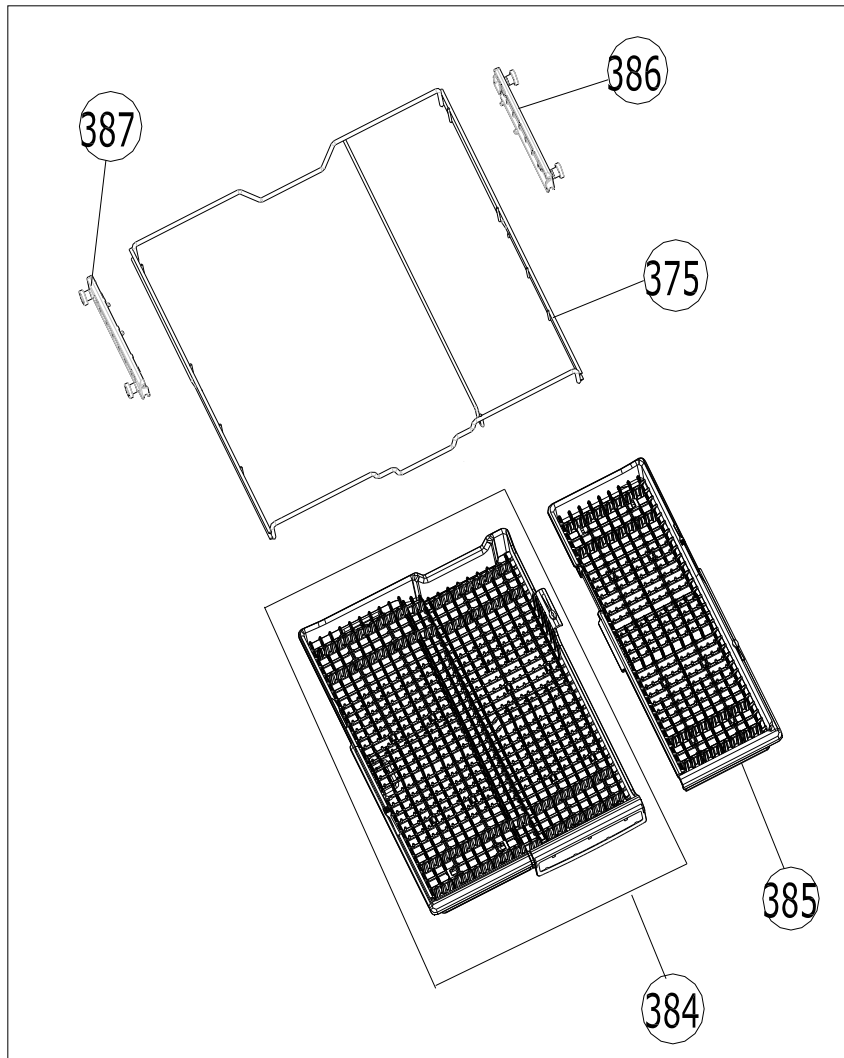

NO	PART NAME
384	3.BASKET LARGE BASKET SHELF GR-PATTERN
385	3.BASKET SMALL BASKET SHELF
375	3.BASKET FRAMEWORK WIRE APPARATUS-R7452
386	3.BASKET WHEEL HOLDER GR-RIGHT
387	3.BASKET WHEEL HOLDER GR-LEFT



WHITE GOODS

VESTEL DISWASHER MACH .

CONTROL PANEL GROUP

CUSTOMER
SUPPORT

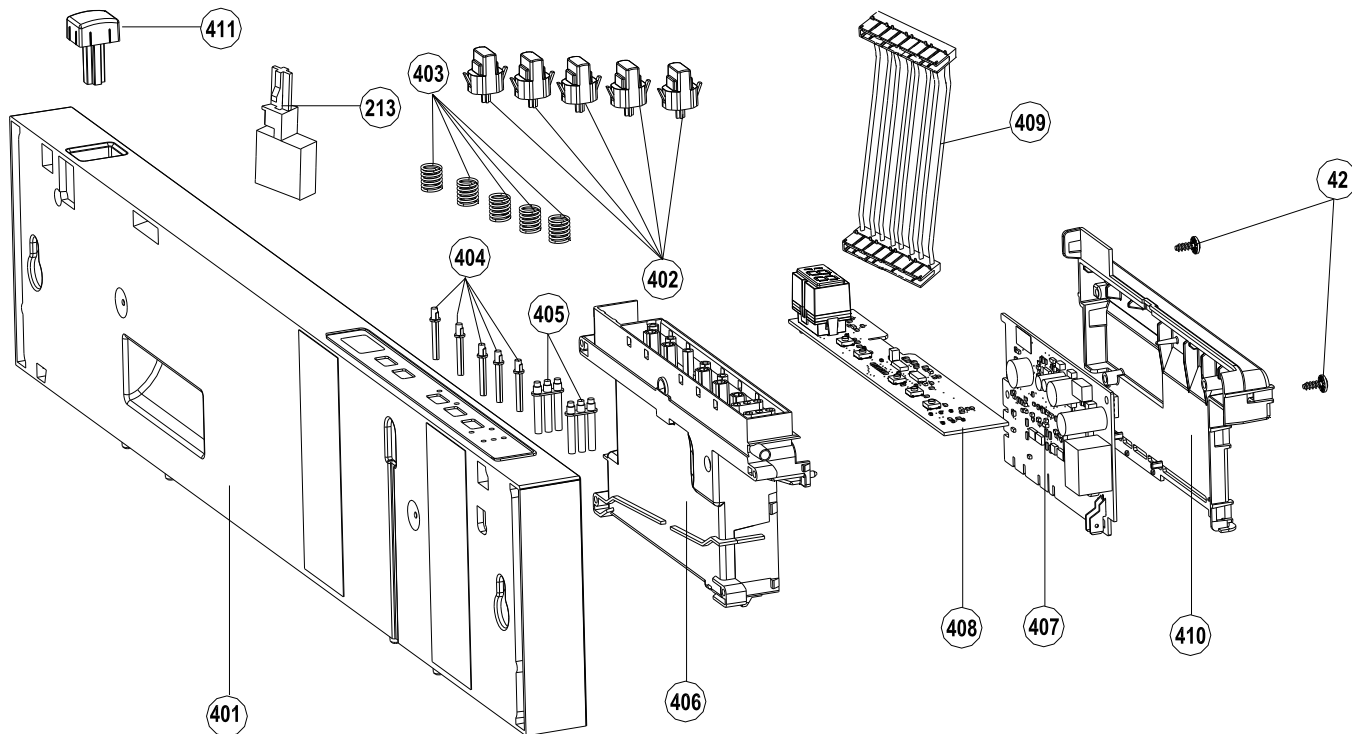

NO	PART NAME
400	CON.PAN.GROUP (401-402-403-404-405-406)
401	CON.PAN.PRINTED
402	ELECTRONIC BUTTON
403	CLICK SPRING
404	LIGHT GUIDE-1
405	LIGHT GUIDE-2
406	PCB BOX
407	ELECT.CARD D41
408	DISPLAY CARD D41
409	INTEGRATED.DISPLAY CABLE
410	PCB BOX COVER
42	SCREW PT3,5X9 YSB
411	ON/OFF BUTTON
213	ON/OFF SWITCH

APRIL 2012

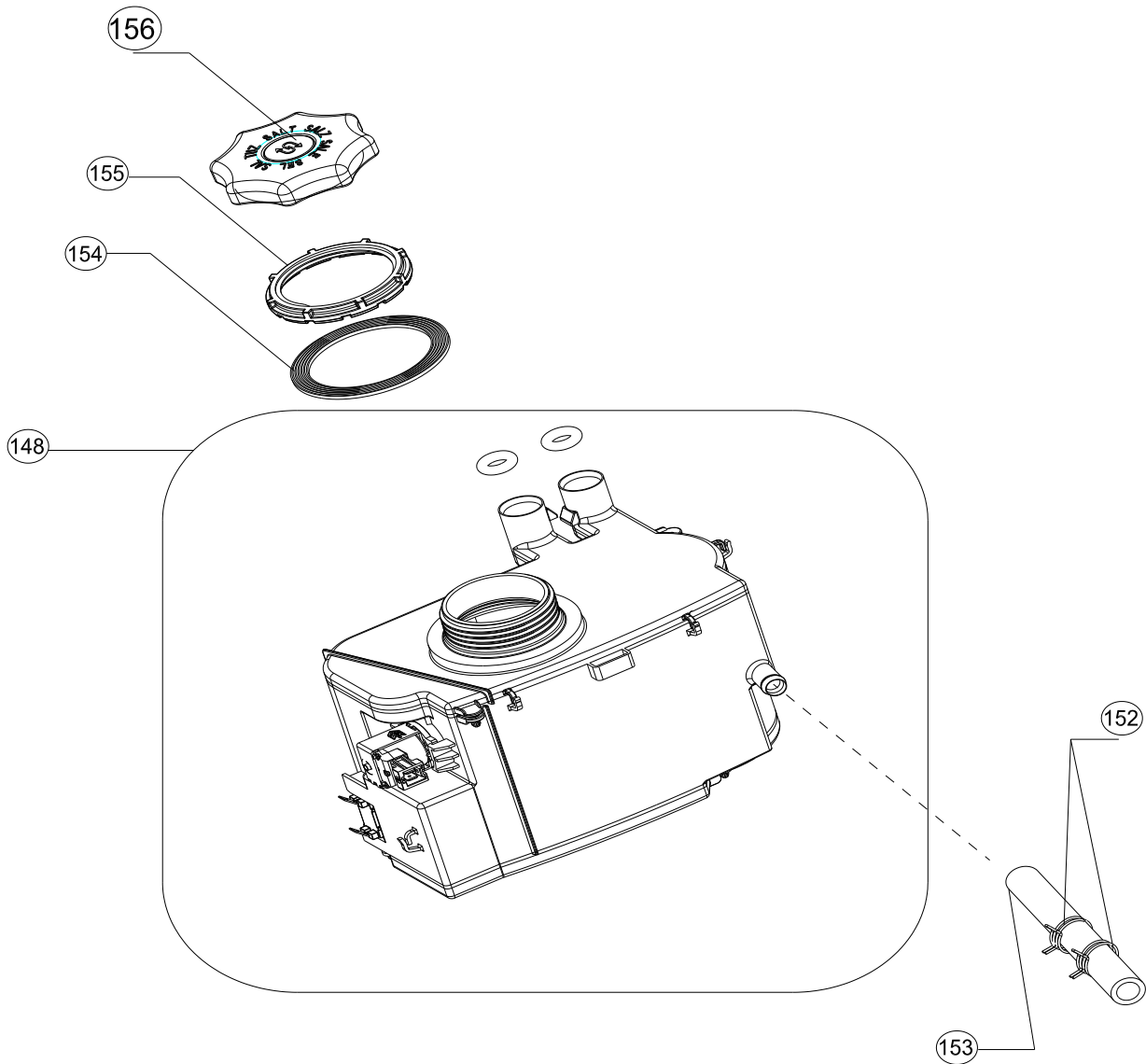

NO	PART NAME
148	WATER SOFTENER GR.WITH REED RELAY (151)
152	CLAMP Dmax19,6X8,8
153	HOSE D12*3*160
154	WATER SOFTENER NUT GASKET
155	WATER SOFTENER NUT
156	SALT CAP GROUP (MAGNETIC VERSION)



WHITE GOODS

VESTEL DISWASHER MACH .

UPPER HYDROLIC GROUP

CUSTOMER
SUPPORT

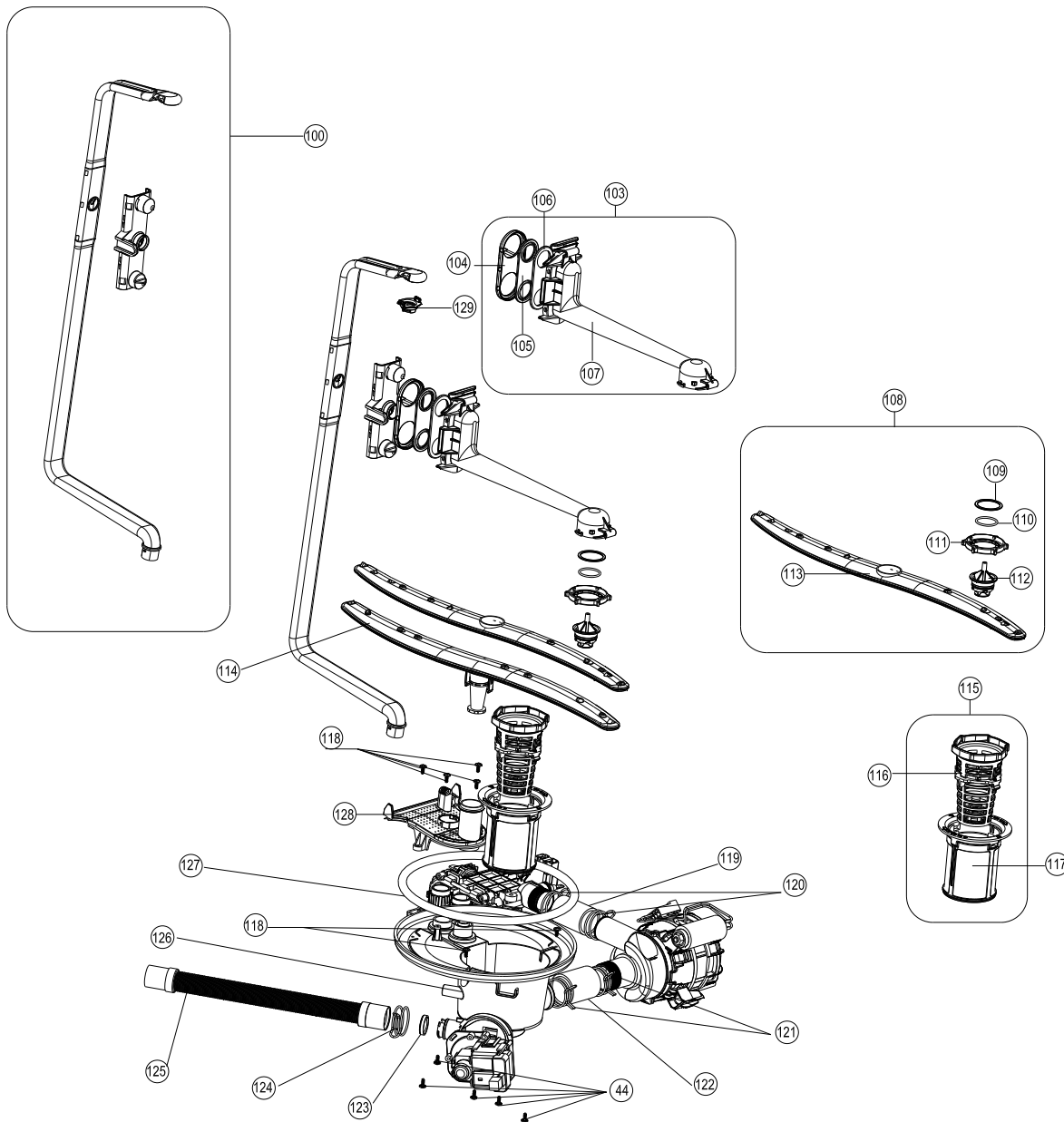

NO	PART NAME
100	UPPER SPRAY ARM FEEDING CANAL GROUP-C
103	UPPER SPRAY ARM SUPPORT GROUP(104-105-106-107)
104	UPPER SPRAY ARM ADAPTER COVER
105	UPPER SPRAY ARM ADAPTER GASKET
106	UPPER SPRAY ARM ADAPTER FLANGE
107	UPPER SPRAY ARM SUPPORT
108	UPPER SPRAY ARM GROUP(113-112-111-110-109)
109	UPPER SPRAY ARM NUT PLASTIC
110	UPPER SPRAY ARM SHAFT O-RING
111	UPPER SPRAY ARM NUT
112	UPPER SPRAY ARM SHAFT
113	UPPER SPRAY ARM

NO	PART NAME
114	LOWER SPRAY ARM
115	MICROFILTER GROUP(116-117)
116	COURSE FILTER
117	MICROFILTER
118	SCREW PT4X12 YSB INOX
119	HOSE D28,5X3
120	CLAMP Dmax36,4X14
121	CLAMP Dmax41X14,8
122	HOSE D33X3
123	KLAPE
124	CLAMP Dmax29,4X11,4)
125	DRAIN HOSE 200 CM
126	SUMP
127	SUMP SEAL
128	SPRAY ARM SUPPORT
129	TOP NOZZLE
44	SCREWPT4X12YSB

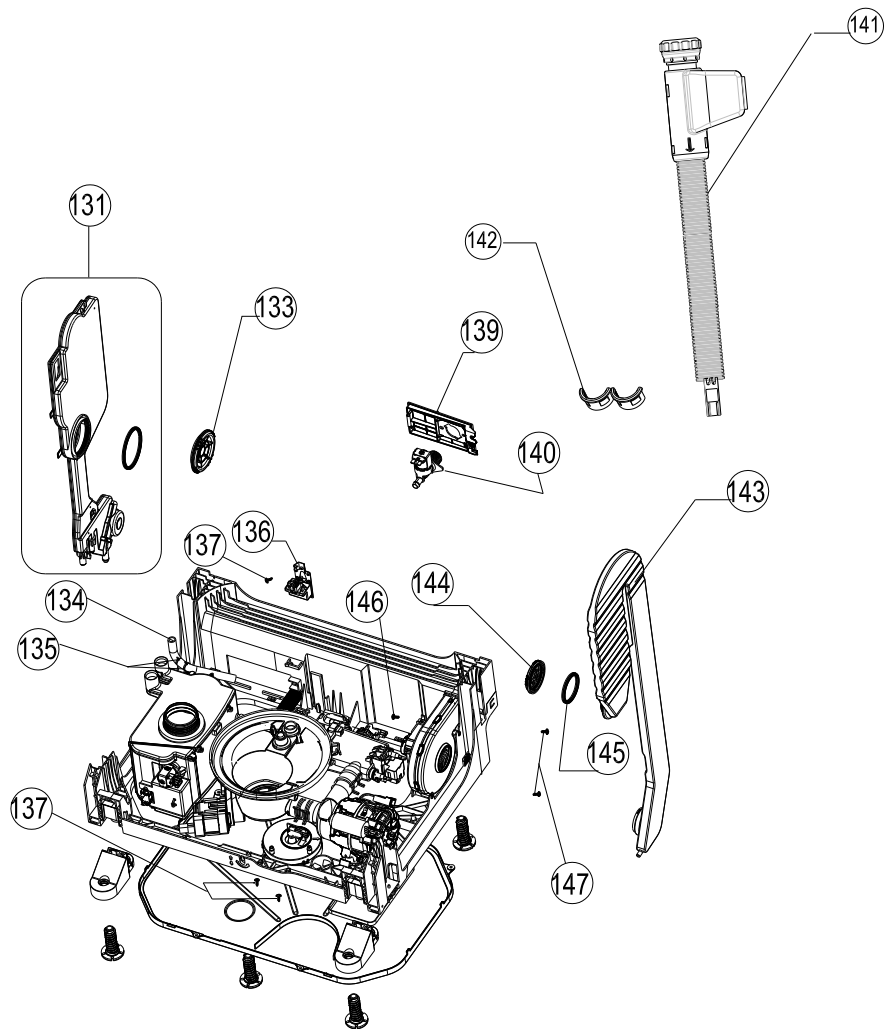

NO	PART NAME
131	AIR BREAK GROUP
133	AIR BREAK NUT
134	HOSE D10*3*230 PVC/WITH CORD
135	CLAMP Dmax16,8x8,4
136	PARASITE FILTER
137	SCREW PT3X9 YSB
139	BASEMENT HOSE CON.PLS.
141	SAFETY HOSE
142	SAFETY HOSE HOLDER
143	STEAM CONDERSER
144	STEAM CONDERSER NUT
145	STEAM CONDERSER SEALING GASKET
146	SCREW PT4X14YSB KEY HEAD 7MM
147	SCREW PT4X14YSB

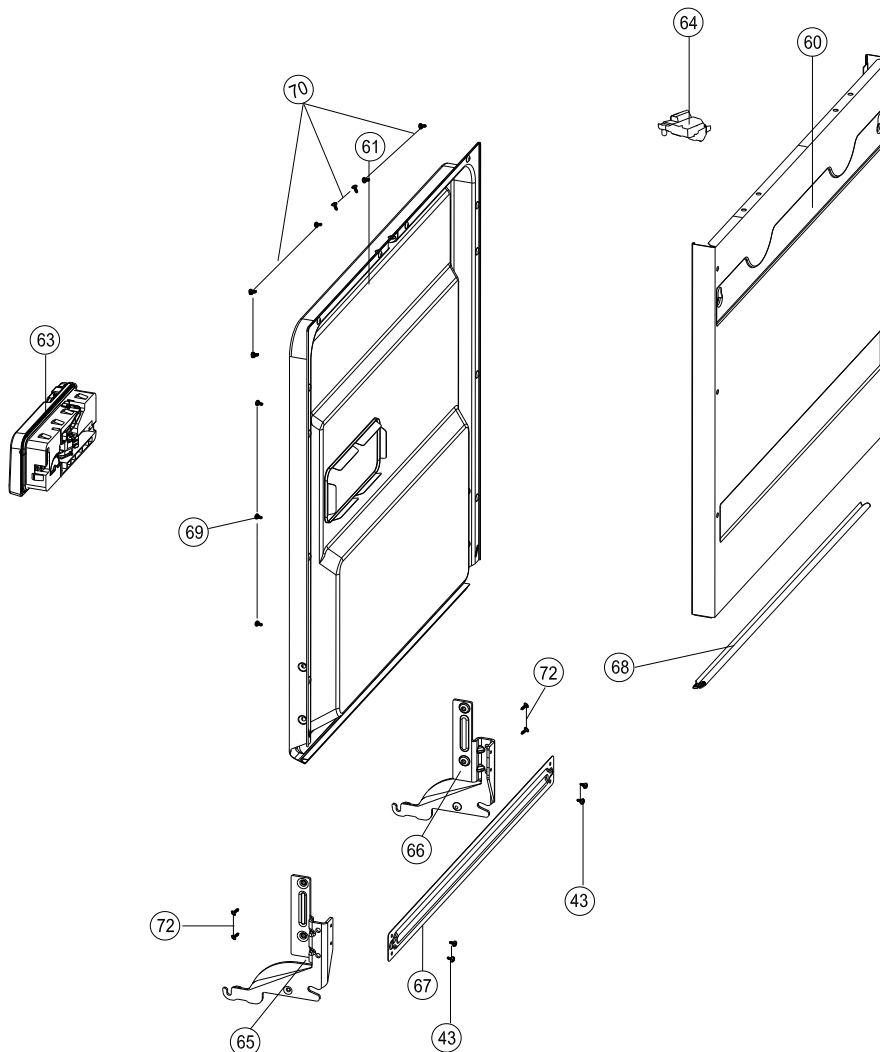

NO	PART NAME
60	FRONT PANEL-7(A527)PR
61	INNER DOOR ASSEMBLY
63	DISPANSER
64	DOOR LOCK
65	HINGE MOVEMENT SHEETIRON LEFT
66	HINGE MOVEMENT SHEETIRON RIGHT
67	TWISTED SHEETIRON
68	DOOR SEAL
69	SCREW ST 3,9X12 FLAT HEAD INOX
70	SCREW PT4X14 FLAT HEAD INOX
72	SCREW M5X10 TORK HEAD (S)
43	SCREW M4X9 PAN HEAD (S)
44	SCREW PT 4X12 PAN HEAD COLLAR CROSS

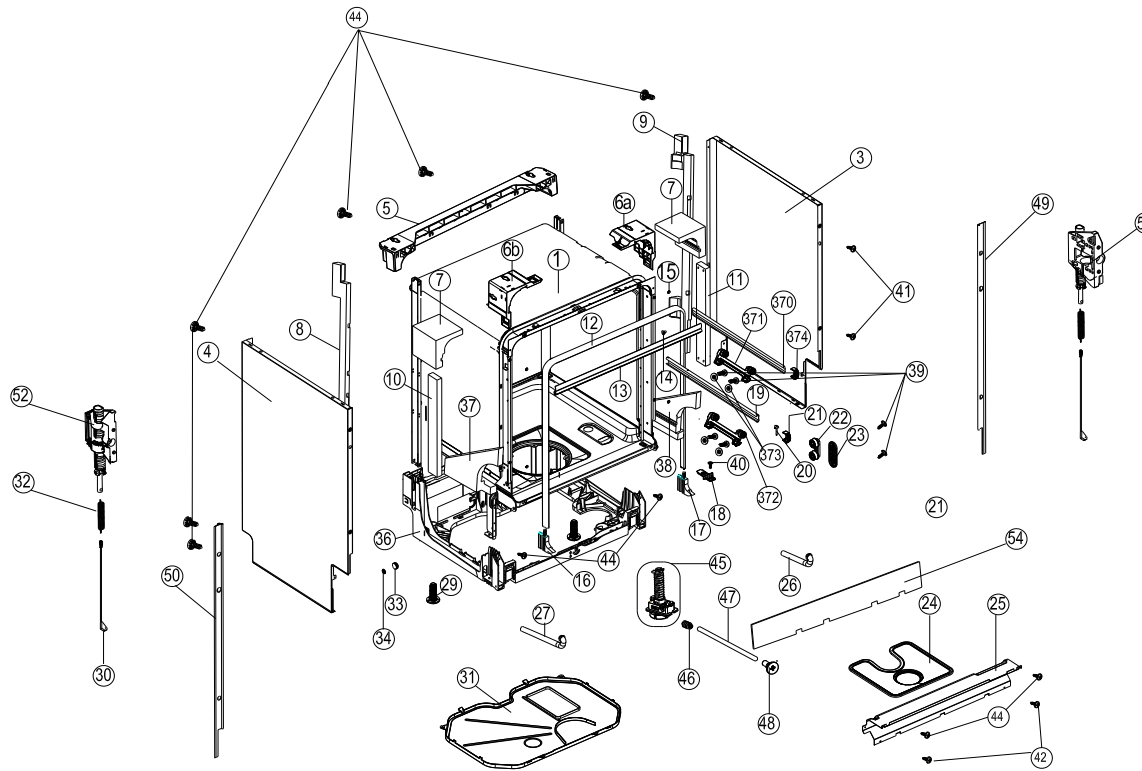

NO	PART NAME
1	TUBE ASSEMBLY
3	PANEL SHEETIRON-RIGHT
4	PANEL SHEETIRON-LEFT

NOTE-1: The spare part with poz no 14 is not valid from 06.2011
NOTE-2: The spare part with poz no 16 and17 is not valid from29.05.2012
NOTE-3: The spare part with poz no 15 is not valid from 09.07.2012

5	REAR UPPER PLS.CROSS BAR
6a	UPPER TRAY SUPPORT PART-RIGHT
6b	UPPER TRAY SUPPORT PART-LEFT
7	TUB TOP CORNER STYROFOAM
8	BACK CROSS BAR STYROFOAM-LEFT
9	BACK CROSS BAR STYROFOAM-RIGHT
10	FRONT CROSS BAR STYROFOAM-LEFT
11	FRONT CROSS BAR STYROFOAM-RIGHT
12	TUB GASKET
13	TOB TUB GASKET
14	TUB HOLE PLUG
15	SIDE PANEL FRONT CROSS BAR SCREW CUPS
16	BOTTOM CORNER GASKET-LEFT
17	BOTTOM CORNER GASKET-RIGHT
18	LATCH DOOR
19	UPPER BASKET RAIL
20	UPPER BASKET STOPPER-REAR
21	UPPER BASKET RAIL LOCK-FRONT
22	UPPER BASKET RAIL CON.BRA.GROUP
23	UPPER BASKET RAIL CON.BRA.GROUP
24	METAL/PLASTIC FILTER
25	KICK PLATE SHEETIRON
26	OVERFLOW PIECE FROM TUB WITH HOSE/300MM
27	OVERFLOW PIECE FROM TUB WITH HOSE/450MM
29	ADJUSTED FOOT
30	HINGE CORD GROUP
31	LOWER COVER
32	HINGE SPRING
33	HINGE PULLEY
34	FIXED PULLEYC SEG. (THE SPARE PART WITH POZ NO 34 IS NOT VALID FROM 01.04.2013)
36	BASEMENT
37	TUB LOWER CORNER STYFROFOAM-LEFT
38	TUB LOWER CORNER STYFROFOAM-RIGHT
39	SCREW DPT5X20 WN 5451 COLLAR CROSS
40	SCREW M4X6 SB
41	SCREW SAC 3,9X7,5 Y
42	SCREW PT3,5X9YSB(F.LI VE T.)
44	SCREW PT4X12 YSB (F.LI
45	BUILT IN ADJUSTMENT MECHANISM
46	BUILT IN WORM GEAR
47	BUILT IN HEIGHT MEC.AXLE
48	BUILT IN ADJUSTMENT MEC.FRONT COVER
49	TUB BORDER GASKET-RIGHT
50	TUB BORDER GASKET-LEFT
51	BUILT IN HINGE SPRING ADJUSTMENT GR.RIGHT
52	BUILT IN HINGE SPRING ADJUSTMENT GR.RIGHT
54	BASEMENT FRONT COVER
370	3.BASKET RAIL
371	3.BASKET BRACKET GR-RIGHT
372	3.BASKET BRACKET GR-LEFT
373	3.BASKET BRACKET WASHER
374	3.BASKET RAIL LOCK-FRONT



VESTEL DISWASHER MACH .

COMPONENTS

CUSTOMER SUPPORT

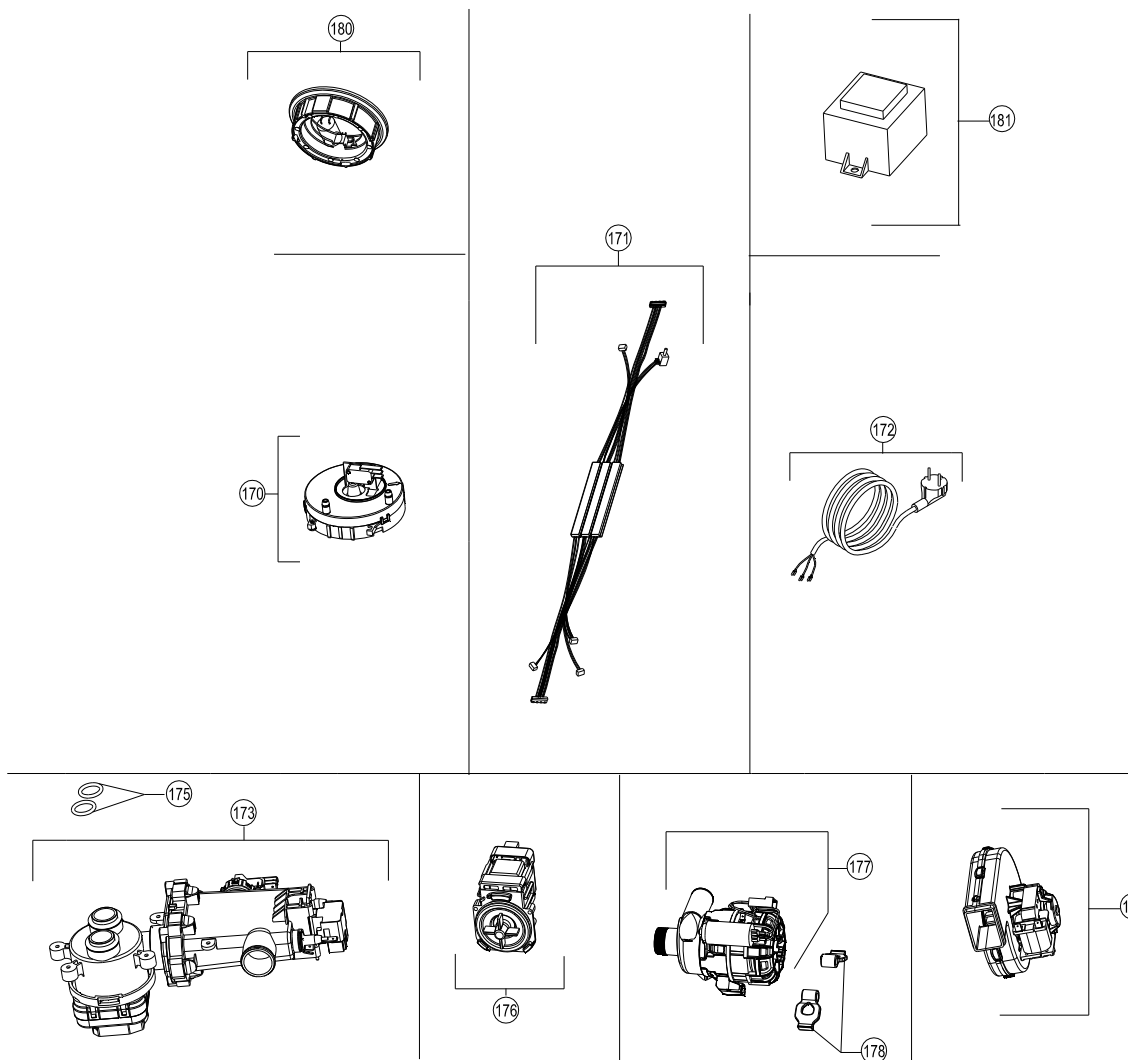

NO	PART NAME	QUANTITY
170	FLOATER	1
171	CABLE HARNESS	1
172	POWER CABLE 180cm/WHITE	1
173	HEATER CASING WITH DIVERTER	1
175	HEATER CASING O-RING	2
176	DRAIN PUMP	1
177	WASHING PUMP	1
178	WASHING PUMP VINE SUPPORT	2
179	TURBO FAN	1
180	LED MODULE	1
181	LED MODULE TRANSFORMER/GT	1



VESTEL DISWASHER MACH .

CUSTOMER
SUPPORT

OPTIONAL PARTS

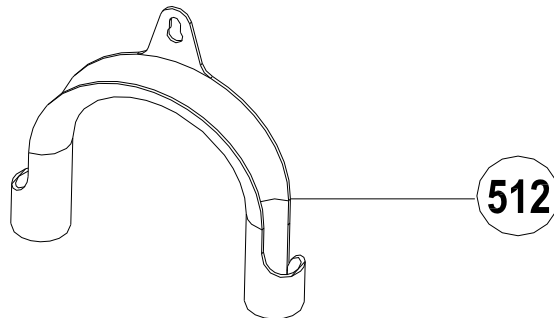
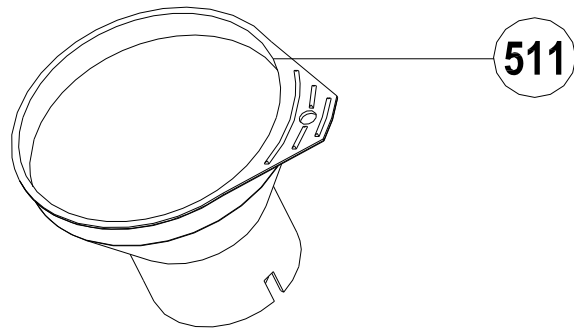

NO	PART NAME
511	SALT FUNNEL
512	DRAIN HOSE COAT RACK

APRIL 2012