

				109	外门	out door	1
				108	控制面板贴面	control panel cover sticker	1
				107	显示窗	screen cover	1
				106	按键弹簧	button spring	5
				105	按键	button	5
				104	控制面板	control panel	1
				103	把手盖	doorknob cover	1
				102	显示板	display pcb	1
				101	防水盖	waterproof cover	1
No.	物料名称	Description	Qty.	No.	物料名称	Description	Qty.

WQP12-7709C

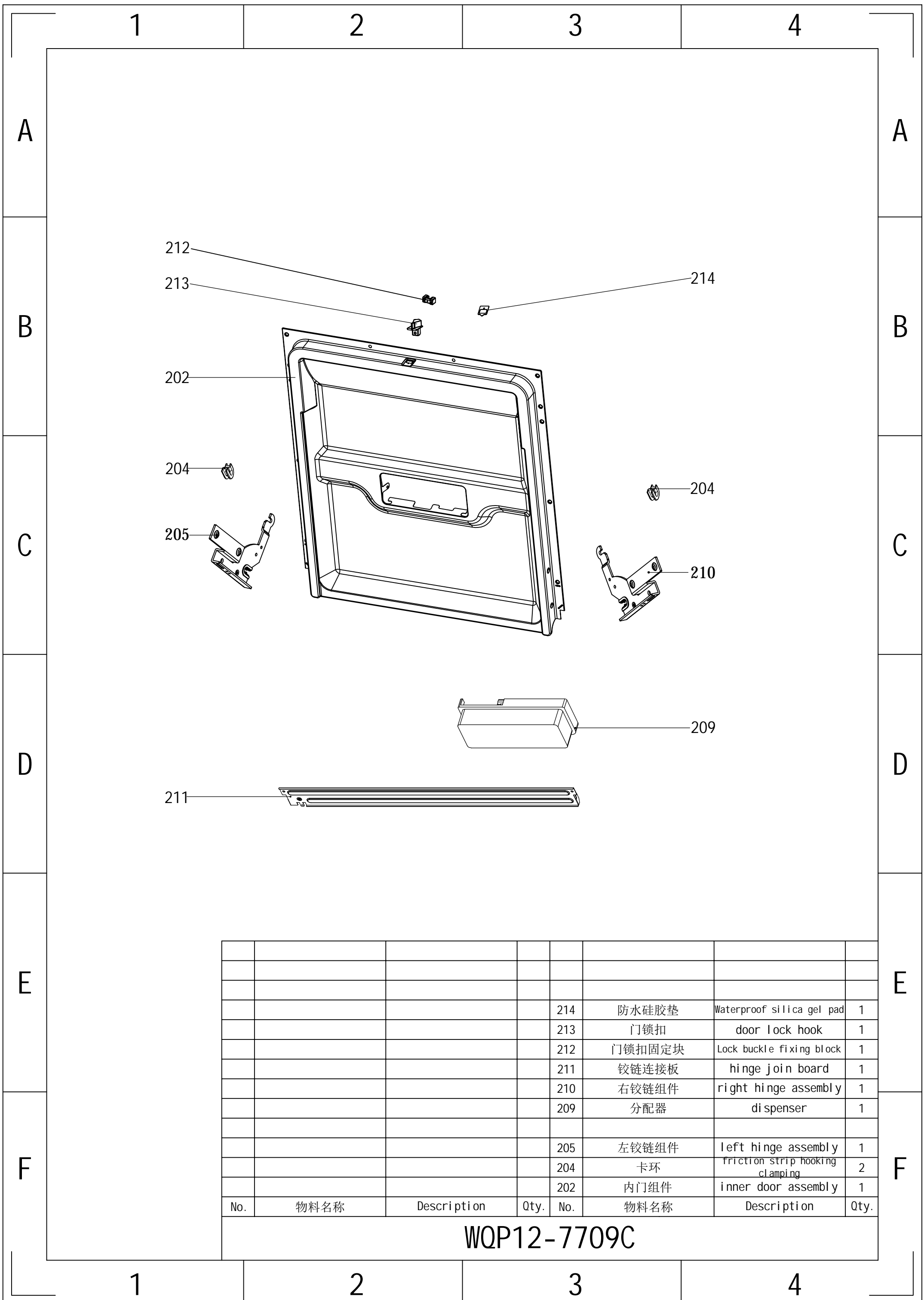

				214	防水硅胶垫	Waterproof silica gel pad	1
				213	门锁扣	door lock hook	1
				212	门锁扣固定块	Lock buckle fixing block	1
				211	铰链连接板	hinge join board	1
				210	右铰链组件	right hinge assembly	1
				209	分配器	dispenser	1
				205	左铰链组件	left hinge assembly	1
				204	卡环	friction strip hooking clamping	2
				202	内门组件	inner door assembly	1
No.	物料名称	Description	Qty.	No.	物料名称	Description	Qty.

WQP12-7709C

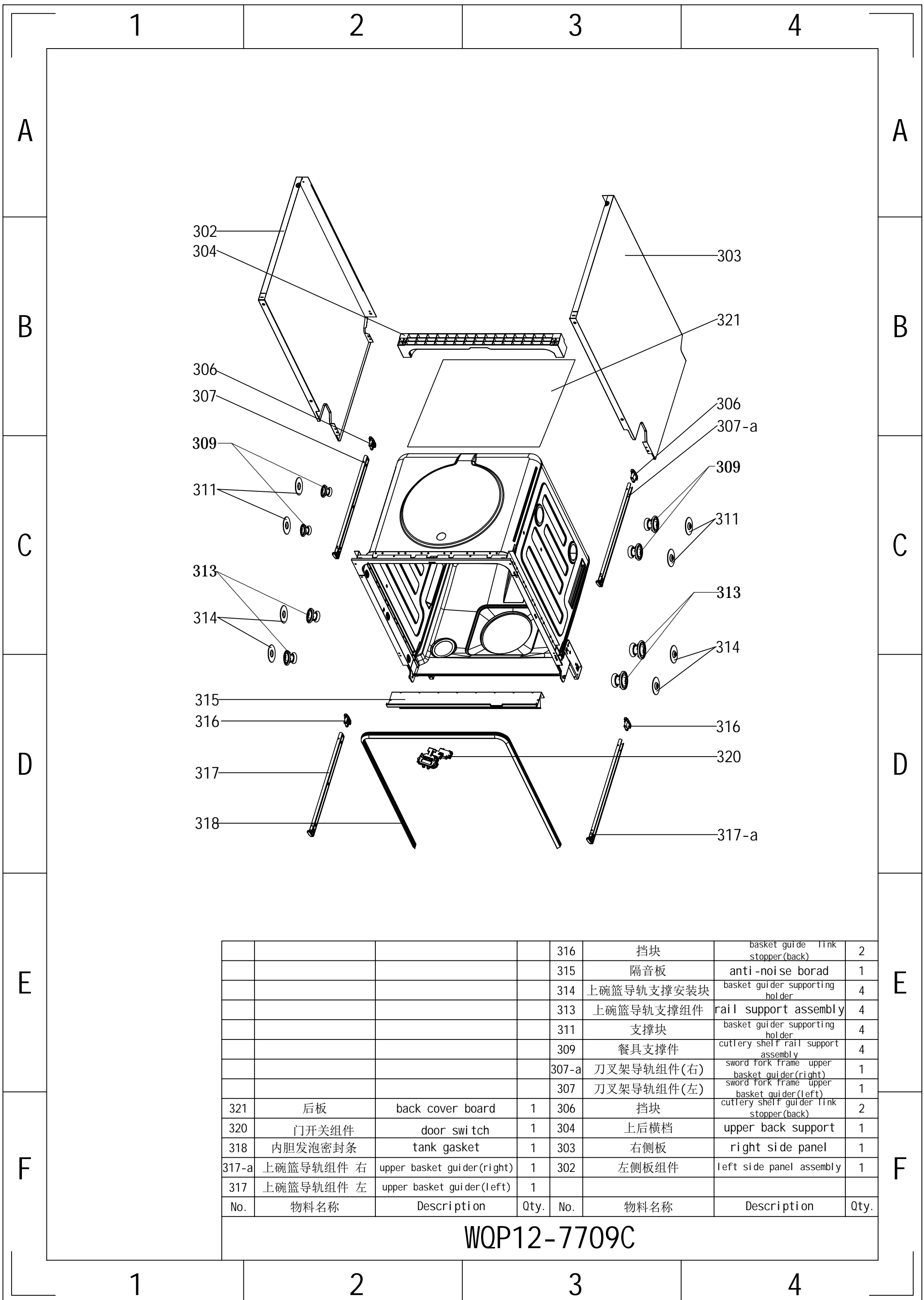

				316	挡块	basket guide link stopper(back)	2
				315	隔音板	anti-noise board	1
				314	上碗篮导轨支撑安装块	basket guider supporting holder	4
				313	上碗篮导轨支撑组件	rail support assembly	4
				311	支撑块	basket guider supporting holder	4
				309	餐具支撑件	cutlery shelf rail support assembly	4
				307-a	刀叉架导轨组件(右)	sword fork frame upper basket guider(right)	1
				307	刀叉架导轨组件(左)	sword fork frame upper basket guider(left)	1
321	后板	back cover board	1	306	挡块	cutlery shelf guider link stopper(back)	2
320	门开关组件	door switch	1	304	上后横档	upper back support	1
318	内胆发泡密封条	tank gasket	1	303	右侧板	right side panel	1
317-a	上碗篮导轨组件 右	upper basket guider(right)	1	302	左侧板组件	left side panel assembly	1
317	上碗篮导轨组件 左	upper basket guider(left)	1				
No.	物料名称	Description	Qty.	No.	物料名称	Description	Qty.

WQP12-7709C

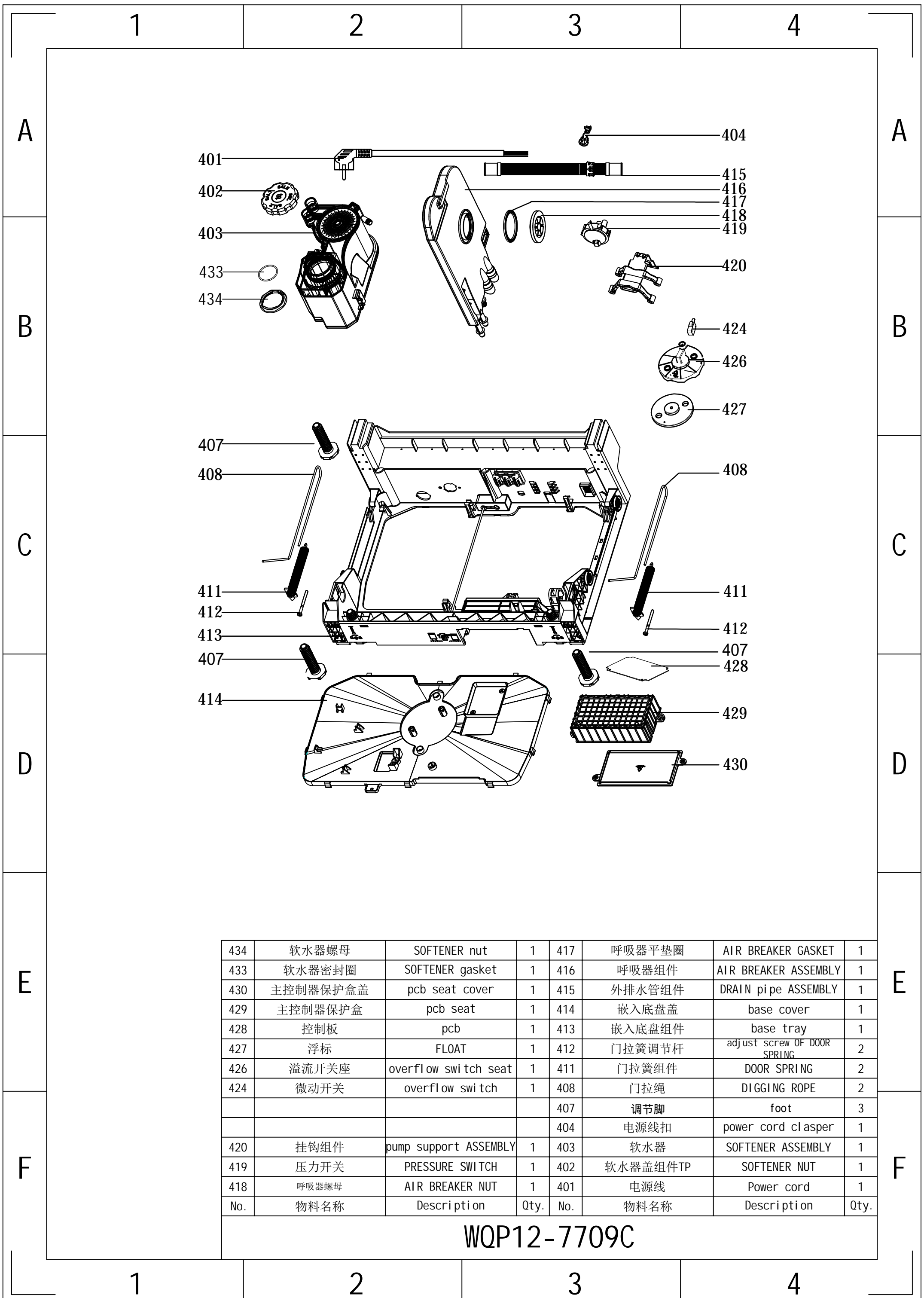

434	软水器螺母	SOFTENER nut	1	417	呼吸器平垫圈	AIR BREAKER GASKET	1
433	软水器密封圈	SOFTENER gasket	1	416	呼吸器组件	AIR BREAKER ASSEMBLY	1
430	主控制器保护盒盖	pcb seat cover	1	415	外排水管组件	DRAIN pipe ASSEMBLY	1
429	主控制器保护盒	pcb seat	1	414	嵌入底盘盖	base cover	1
428	控制板	pcb	1	413	嵌入底盘组件	base tray	1
427	浮标	FLOAT	1	412	门拉簧调节杆	adjust screw OF DOOR SPRING	2
426	溢流开关座	overflow switch seat	1	411	门拉簧组件	DOOR SPRING	2
424	微动开关	overflow switch	1	408	门拉绳	DIGGING ROPE	2
				407	调节脚	foot	3
				404	电源线扣	power cord clasper	1
420	挂钩组件	pump support ASSEMBLY	1	403	软水器	SOFTENER ASSEMBLY	1
419	压力开关	PRESSURE SWITCH	1	402	软水器盖组件TP	SOFTENER NUT	1
418	呼吸器螺母	AIR BREAKER NUT	1	401	电源线	Power cord	1
No.	物料名称	Description	Qty.	No.	物料名称	Description	Qty.

WQP12-7709C

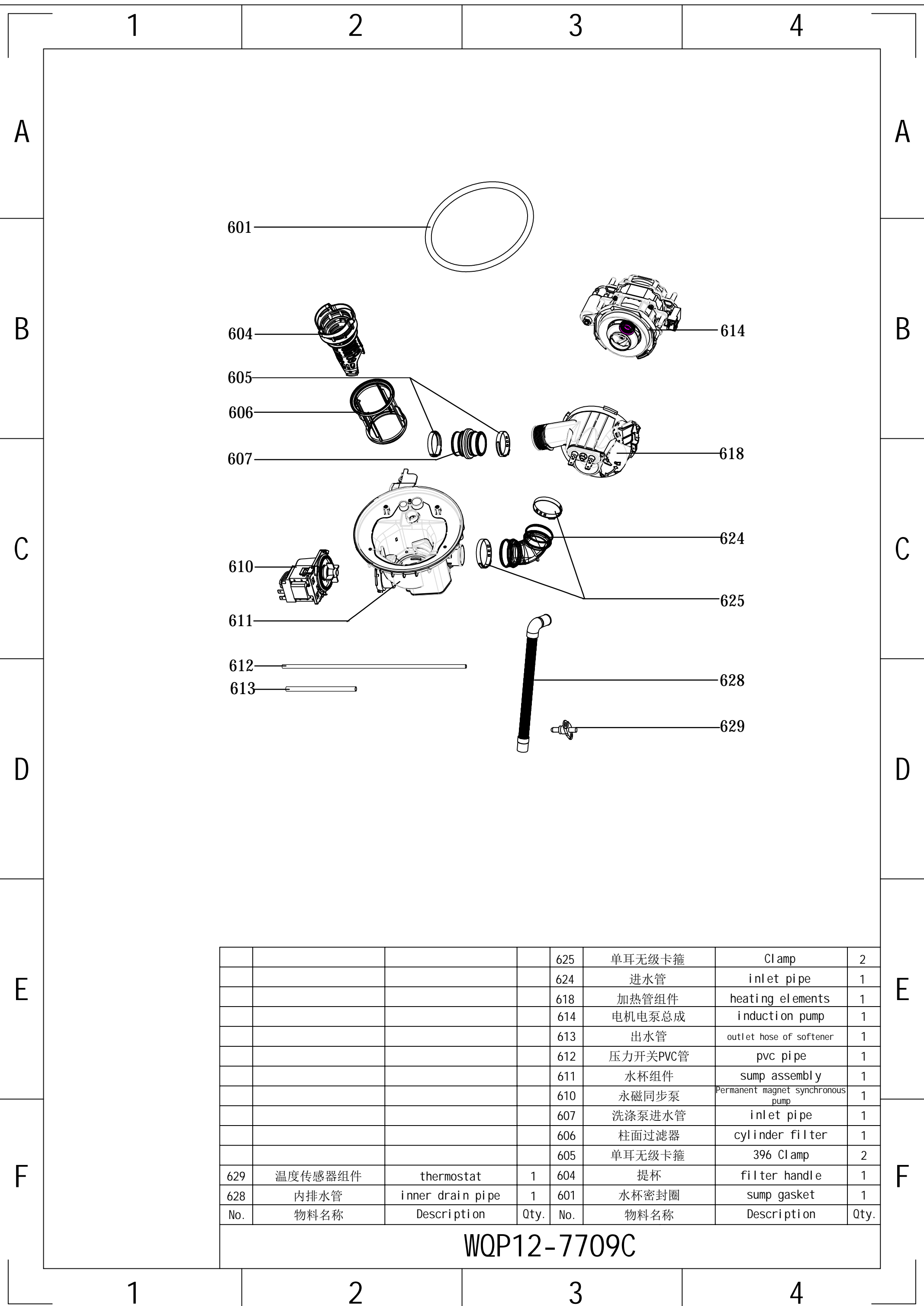

				625	单耳无级卡箍	Clamp	2
				624	进水管	inlet pipe	1
				618	加热管组件	heating elements	1
				614	电机电泵总成	induction pump	1
				613	出水管	outlet hose of softener	1
				612	压力开关PVC管	pvc pipe	1
				611	水杯组件	sump assembly	1
				610	永磁同步泵	Permanent magnet synchronous pump	1
				607	洗涤泵进水管	inlet pipe	1
				606	柱面过滤器	cylinder filter	1
				605	单耳无级卡箍	396 Clamp	2
629	温度传感器组件	thermostat	1	604	提杯	filter handle	1
628	内排水管	inner drain pipe	1	601	水杯密封圈	sump gasket	1
No.	物料名称	Description	Qty.	No.	物料名称	Description	Qty.

WQP12-7709C

1

2

3

4

A

A

B

B

C

C

D

D

E

E

F

F

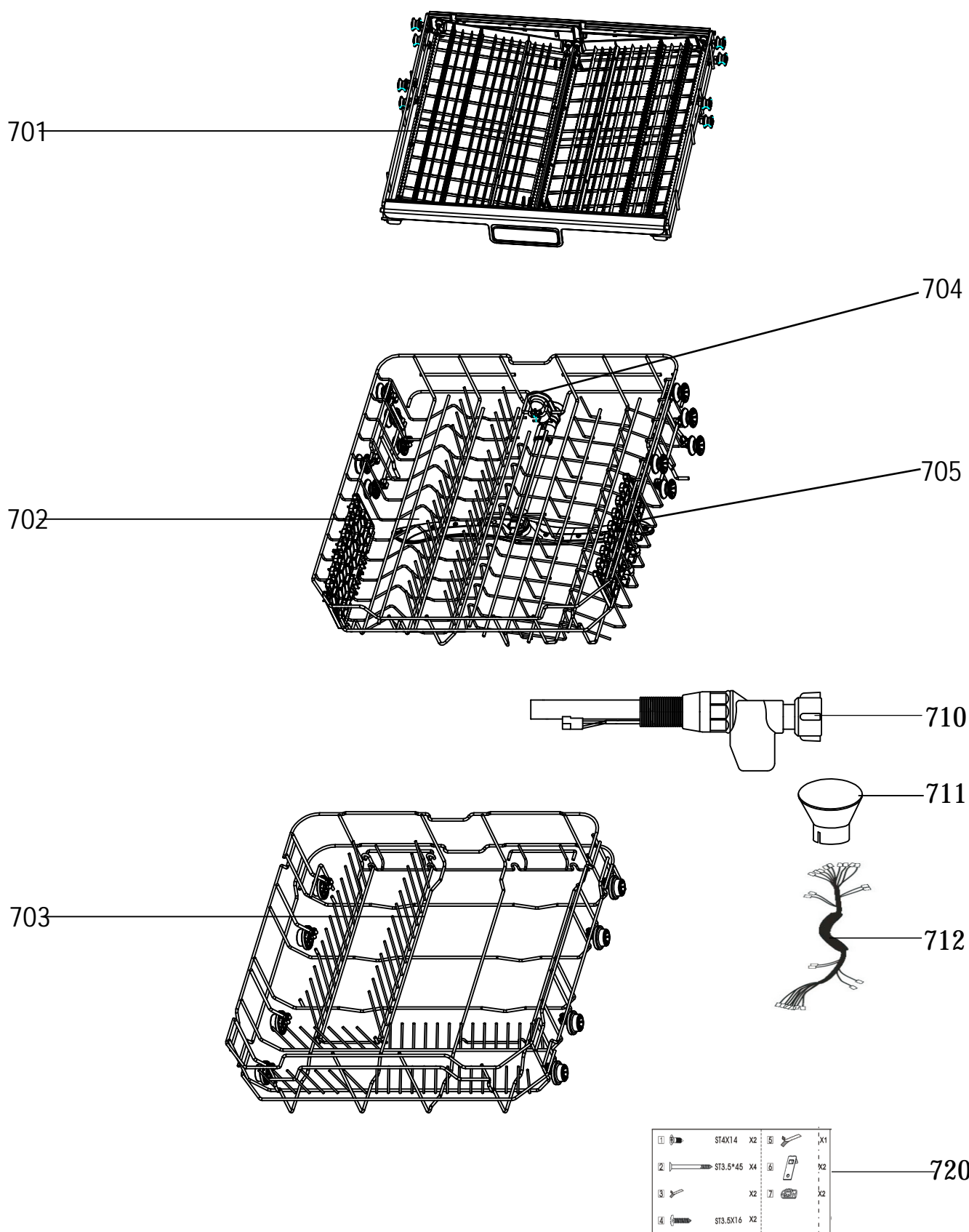

				720	附件包	accessory bag	1
				712	线束	wiring harness	1
				711	盐斗	salt filler	1
				710	进水管组件	inlet hose assembly	1
				705	杯托	cup rack	2
				704	中喷臂组件	MIDDLE SPAYER ASSEMBLY	1
				703	下碗篮组件	lower basket assembly	1
				702	上碗篮组件	Upper basket	1
				701	刀叉托盘组件	cutlery assembly	1
No.	物料名称	Description	Qty.	No.	物料名称	Description	Qty.

WQP12-7709C

1

2

3

4